

Ratio Smart/Solar Charger

MANUAL



Thank you for choosing the Ratio Smart/Solar Charger

Manufacturer

Ratio Electric B.V.

Ambachtsstraat 12
NL - 3861 RH Nijkerk
The Netherlands
Tel. +31-33-2452360
info@ratio.nl
www.ratio-electric.com

UK English - Original
EV082 - V02 - 02/2023

Preface

About this document

This manual contains technical descriptions and instructions for the following product:

Category of product	Charger for Electric Vehicles
Product name	Smart/Solar Charger
Art. No.	388xx
Hardware version	Charger5
Serial number	

Write down the serial number of your product in the table above for future reference.

This manual contains all instructions and safety information for installation, commissioning, use and maintenance of the product.

This manual is intended for:

- the qualified technician who installs the product;
- the end-user who uses the charger;
- the product owner who maintains the product.

Original instructions

This manual has been translated into multiple languages. The original manual is written in UK English. All other language versions are translations of the original manual.

Copyright

The content of this manual is protected by copyright and other intellectual property laws.

The content of this manual may only be copied, modified, reproduced, translated with express written permission from the manufacturer. This manual may only be published, transmitted, displayed or made available to a third party with express written permission from the manufacturer.

Disclaimer of liability

Ratio Electric B.V. cannot be held responsible for personal injury, damage to the product or property damage caused by incorrect use, foreseeable misuse or failure to follow the instructions in this manual. This also applies to unauthorized modifications of the product and the use of non-approved spare parts, tools or accessories.

Ratio Electric B.V. reserves the right to modify this manual without notification beforehand.

Table of contents

1. Safety	5	6. Commissioning	32
1.1. Symbols and labels	5	6.1. Note down the unique passcode of the charger	32
1.2. Intended use	6	6.2. Download the Ratio EV Charging App	33
1.3. Reasonably foreseeable misuse	6	6.3. Initial configuration of the charger	33
1.4. Qualification of personnel	6	6.4. Overview of the Ratio EV Charging App	35
1.5. Personal protective equipment	7	6.5. Connect the charger to the Ratio EV Charging App	35
1.6. Safety precautions	7	6.6. Testing solar charging functionality	36
2. Description of the product	9	6.7. Updating the charger	36
2.1. Charger components	10	7. Use	37
2.2. Sensorbox components (Optional for Smart charger)	11	7.1. Start charging	37
3. Technical data	12	7.2. During charging	37
3.1. Nameplate/Marking	13	7.3. Stop charging	38
4. Transport and storage	13	8. Settings	38
4.1. Transport	13	9. Maintenance	39
4.2. Storage	13	10. Troubleshooting	40
5. Installation	14	11. Service	41
5.1. Preparation	14	12. Data protection	42
5.2. Install the power cable in the consumer unit	16	13. Warranty	42
5.3. Install the Sensorbox in the consumer unit	16	14. Disposal	42
5.4. Connect the power cable to the charger	21	EC Declaration of Conformity	43
5.5. Install the data cable in the charger	24		
5.6. Install a data cable between two chargers for Power Sharing	27		
5.7. Checks before finishing the installation	31		
5.8. Finish the installation	31		

1. Safety

Please make sure you have fully read and understood the instructions in this manual before you start installing or using the product. If you fail to follow the instructions from this manual you can put persons, surroundings, the environment and the product at risk. Store this manual in an accessible place near the product for future reference.



Always comply with the information, such as labels and the nameplate, attached directly to the product and keep the information in a legible condition.

Always comply with any applicable laws and regulations that have not been accounted for in this manual.

1.1. Symbols and labels

1.1.1. Safety warnings

This manual contains safety warnings that may result in injury when ignored. Each safety warning is indicated with a signal word. The signal word corresponds with the level of risk of the described hazardous situation, see the table below.

Signal word	Risk of injury	Result when instruction is ignored or not followed correctly
 WARNING	Medium	Could result in death or serious injury
 CAUTION	Low	Could result in minor or moderate injury

Safety warnings at the start of a section, apply to the entire section.

Safety warnings that refer to a particular sentence or procedure step are embedded in the running text.

1.1.2. Notices

Messages that are not hazard-related are indicated with the signal word **NOTICE**. These messages do not have a safety alert symbol.

Signal word	Meaning
NOTICE	Could result in damage to the product when instruction is ignored or not followed correctly
Note	Additional information or emphasis on an instruction

1.2. Intended use

The Ratio Smart/Solar Charger is both a non-restricted and restricted charger intended to charge electrical vehicles using power from solar panels and the household power grid. The product can be operated indoors and outdoors.

The product must only be operated within its performance limits and under the permitted ambient conditions, as stated in the technical specifications in chapter 3.

The product can be mounted flush to a wall, or to a separately available pole for pavement or soil.

Safe use of the product is only guaranteed if it is used as intended.

1.3. Reasonably foreseeable misuse

The following is considered foreseeable misuse:

- Use in an environment that varies from or exceeds the given environmental conditions.
- Use that varies from or exceeds the given operating conditions.
- Failure to comply with the instructions in this manual.
- Failure to eliminate faults, malfunctions or defects of the product that impose safety risks.
- Failure to carry out the inspections and maintenance operations as described in this manual.
- Unauthorised removal or modification of parts or safety devices of the product.
- Use of spare parts or accessories that have not been approved by the manufacturer.
- Operation in a flammable and/or explosive environment.
- Operation in closed-off or poorly ventilated rooms.

1.4. Qualification of personnel

Only authorised technicians are allowed to perform installation and maintenance of the product. They must possess the following qualifications:

- are legal of age;
- are familiar and abide by the safety instructions and sections of this manual related to installation and maintenance of the product;
- are familiar with and abide by the applicable local, national and international laws and regulations;
- are able to recognise the possible dangers of the product and take the necessary measures to protect persons and property;
- have received adequate training in the safe installation and maintenance of this product;
- have obtained authorisation to access the product.

1.5. Personal protective equipment

Wear the appropriate personal protective equipment (PPE) according to the manual of any tools you use during installation of the charger.

Wear insulating gloves when installing wires and touching electrical components to avoid damaging the product by static discharge.

1.6. Safety precautions

Despite the safe design and construction of the product and the prescribed protective measures, the product possesses residual risks. This manual provides safety messages to indicate these risks. The formatting and appearance of safety messages that are dedicated to a particular section or sentence is explained in chapter 1.1.

Read all the safety warnings and instructions before using the product. Failure to follow the warnings and the instructions may result in electric shock, fire and/or serious injury.

WARNING

- This device should be supervised when used around children.
- Do not put fingers into the electric vehicle connector.
- Do not use this product if the flexible power cord or EV cable are frayed, have broken insulation, or any other signs of damage.
- Do not use this product if the enclosure or EV connector are broken, cracked, open, or show any other indication of damage.
- Switch off the MCB in your electrical cabinet and immediately contact Customer Support for service if at any time you think the equipment is unsafe. Do not use your Smart/Solar Charger until the problem is identified and corrected.
- Improper connection of equipment-grounding conductor can result in a risk of electric shock. Check with a qualified electrician or serviceman if you doubt whether the product is properly grounded.
- Do not use this product if it does not function according to the instructions in this manual. Seek advice from Ratio, your vendor, or a qualified electrician or serviceman.
- Do not remove the charging plug while a charging session is active.
- Children should not be allowed to use this product. Do not allow children to play in or around the product.

⚠ CAUTION

- Make certain the supply cable of the product is positioned so it will not be stepped on, tipped over, or otherwise subjected to damage or stress.
- There are no user serviceable parts inside. Refer to the Customer Support section in this manual for service information. Do not attempt to repair or service the product yourself.
- Do not operate this product if it or the supply cable or housing is visibly damaged. Switch off the MCB in the electrical cabinet and contact your Service Representative for service immediately. Refer to the Customer Support section in the manual for information on the Service Representative in your area.
- Only use this product to charge electric vehicles equipped with a conductive charge port. See the vehicle's owner's handbook to determine if the vehicle is equipped with a conductive charge port.
- Use of any adaptors is not allowed with this product.
- Only use certified type 1 or type 2 charging cables with this product.
- Cord extension sets are not allowed to be used.

NOTICE

- Do not drop the product and avoid bumping.
- Do not store the product in an environment that exceeds the ambient conditions as stated in this manual.
- Do not expose the internal components product to moisture.
- Do not immerse the product in water or any other liquid.

2. Description of the product

The Smart/Solar Charger is a Mode 3 charger for charging electrical vehicles (EV) that complies with the IEC61851 standard.

The Smart/Solar Charger is equipped with several features to optimise power consumption and charging performance.

Dynamic Load Balancing

The product uses a Sensorbox with current transformer(s) to measure the live power consumption of the power grid per phase and uses that information to manage the power output to your EV. When more electrical appliances are used, the power output to the EV is reduced to avoid overloading the power grid.

The Sensorbox uses up to three CT clamps, one for each phase of the main grid, to measure the current flow of the main grid. The Sensorbox is also compatible with solar panel installations and can measure the direction of the current.

Power Sharing

If you have purchased more than one charger, you can interconnect the chargers with a data cable and use the integrated **Power Sharing** feature to equally distribute the available power across the chargers points using the data from the Sensorbox.

One charger is connected to the Sensorbox with a data cable. This charger acts as the Main Controller (MAIN), and manages the power for up to three Sub Chargers (SUB1, SUB2 and SUB3).

It is also possible to use Power Sharing without the Sensorbox. It will function without **Dynamic Load Balancing**, the chargers must be connected to each other with a data cable and set in Basic mode.

Note: PureSolar mode is not compatible with **Power Sharing**.

Over the air update

Over the air update (OTA) is possible, your charger can receive the available updates over the internet.

Multiple users and multiple cars

Different users and multiple cars can be added to view the charging sessions of each individual online. A maximum of five users or cars can be created.

Ratio EV Charging App

The charger can be controlled with the Ratio EV Charging App.

The App is available in the Google Play Store and Apple store, or check our website. For more information, go to chapter 6.2.

Charge modes

The charger has four available charge modes:

Basic	The charger charges the EV using a set maximum power in Amps (Maximum charging current). - no Load Balancing .
Smart	The charger only charges the EV when the available power is above the minimum set power in Amps (Minimum charging current) and below the maximum power that is still available on the main grid. *
SmartSolar	The charger only charges the EV when the available power is above the minimum set power in Amps (SmartSolar minimal charging current) and below the maximum power that is still available on the main grid. * If the charger is charging the EV and there is still net power generation, the charger uses this surplus of energy to charge the car in addition to the minimum set power.
PureSolar	The charger only charges the EV when there is a net power generation (e.g. from solar panels), that is above the minimum set power in Amps (Puresolar minimal charging current). *

* Charging at a maximum current while protecting the building from overcurrent loading with Dynamic Load Balancing. While charging at home or an office building the charging current adapts to the maximum allowed consumption in the building.

Note: PureSolar mode is not compatible with **Power Sharing**. If you set the charge mode to PureSolar, **Power Sharing** will be disabled.

2.1. Charger components

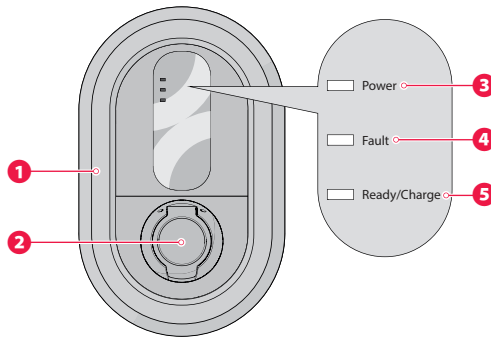

- 1 Front cover ring
- 2 Charge socket

- 3 Power LED
- 4 Fault LED
- 5 Ready/Charge LED

2.2. Sensorbox components (Optional for Smart charger)

Note: The Ratio Smart charger does not include the CT clamps and Sensorbox needed for Dynamic Load Balancing and PV charging. To upgrade your Ratio Smart charger to support Dynamic Load Balancing, purchase Ratio Sense. This package contains a Ratio Sensorbox and CT clamps. Follow the instructions in chapter 5.3. of this manual to install Ratio Sense in your Ratio Smart charger.

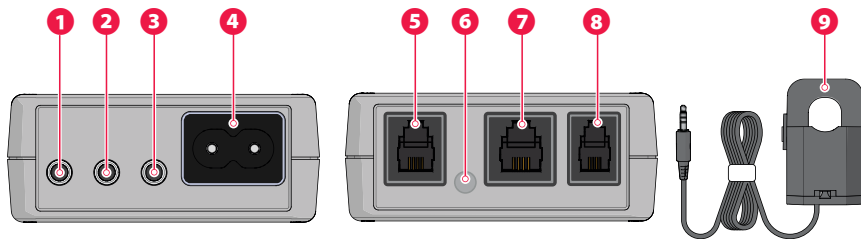

- | | |
|-------------------------------|--|
| 1 Phase 1 (L1) CT clamp input | 6 Status LED |
| 2 Phase 2 (L2) CT clamp input | 7 Input/Output ** |
| 3 Phase 3 (L3) CT clamp input | 8 Data cable connector |
| 4 Mains input* | 9 CT clamp (3× for 3-phase installation) |
| 5 P1 meter input (inactive) | |

* The mains input does not supply power to the Sensorbox. It is used to determine the direction of the measured current. The provided mains input cable must be installed on phase 1 (L1) of the main power grid and is orientation sensitive.

** Not for Ethernet connection.

3. Technical data

Product name	Smart/Solar Charger
Art. no.	388xx
Charging System	IEC61851, Mode 3
Cable version car connector	IEC 62196, type 1 or type 2
Outlet version	IEC 62196, type 2 Outlet
Power input	single-phase or 3 phase, 230V-400V AC, 16A-32A
Max Power output	7,4 kW / 230V AC, 22 kW / 400V AC
Frequency	50 Hz 5%
Protection against electric shock	Class I
Residual current detection	DC 6mA
Dimensions	400 mm × 250 mm × 105 mm
Housing	PC/ABS-VO
Weight	4 kg (incl. cable)
IP Protection rating	IP54, rain-tight
Altitude	Up to 2000 m.
Ambient temperature	-25 °C to +40 °C
External magnetic field	Not exceeding five times the earth's magnetic field in any direction.
Sinusoidal wave distortion	Not exceeding 5%
Relative humidity (maximum value at 40 °C)	75%
Markings	CE
Ventilation	Not supported
Required protection device type	Type A
Required protection device rating	30 mA
Supported connectivity protocols	Bluetooth® wireless technology Wi-Fi Ethernet



3.1. Nameplate/Marking

The product is marked in accordance with the applicable legislation requirements. The nameplate/markings is located on the bottom of the housing, above the cable inlets.

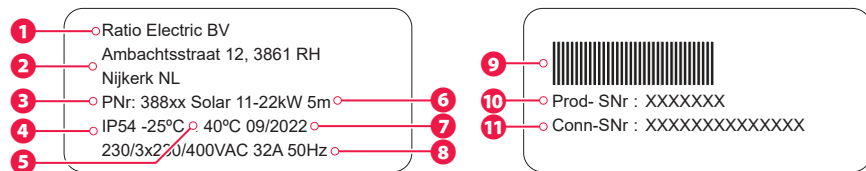

- | | |
|-----------------------------|---|
| 1 Manufacturer | 7 Production date |
| 2 Contact details | 8 Rated input power |
| 3 Product number | 9 Barcode serial number |
| 4 IP rating | 10 Product serial number |
| 5 Ambient temperature range | 11 Connectivity serial number
(visible in App) |
| 6 Product name | |

4. Transport and storage

4.1. Transport

Transport the product in the original packaging, or suitable replacement packaging that provides adequate protection from vibrations, bumps, moisture, dust, and debris. Be careful not to drop the product and prevent it from moving or bumping into objects while transporting. Excessive vibrations could loosen wire connections and cause the product to malfunction.

4.2. Storage

Always disconnect the product from the power supply when storing the product. Store the product in environmental conditions within the limits stated in chapter of 3 this manual. Store the product in the original packaging or a suitable replacement packaging to protect the product from moisture, dust, and debris. Do not store anything on top of the product.

5. Installation

5.1. Preparation

⚠ WARNING

- The installation must be done by a qualified and licensed electrician according the local legislation.
- The electrical installation must be free of power during the entire installation period.
- Since this charger uses circuits that reference to ground, no megging must be done after connecting to power.

5.1.1. Check the contents



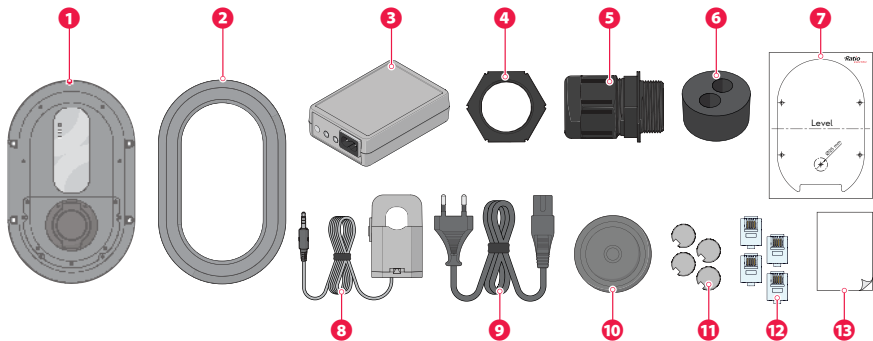



1. Open the box and remove the contents.
2. Place all parts on an empty surface to avoid losing any parts.
3. Check if all parts are present and undamaged using the overview below. In case of any parts missing or damaged, please contact your local dealer or Ratio Electric B.V.

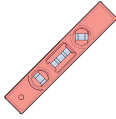

- | | |
|-------------------------------|-----------------------------------|
| 1 Charger | 8 Current transformers |
| 2 Front cover ring | (3x for 3-phase installation) |
| 3 Sensorbox with connector | 9 Mains input cable for Sensorbox |
| 4 Locknut for cable gland | 10 Rubber grommet for data cable |
| 5 M25 cable gland (2x) | 11 Screw caps (4x) |
| 6 Foam insert for data cables | 12 RJ10 connector (4x) |
| 7 Drilling template | 13 Adhesive strip |

Note: The Ratio Smart charger does not include the CT clamps and Sensorbox needed for Dynamic Load Balancing and PV charging. To upgrade your Ratio Smart charger to support Dynamic Load Balancing, purchase Ratio Sense. This package contains a Ratio Sensorbox and CT clamps. Follow the instructions in chapter 5.3. of this manual to install Ratio Sense in your Ratio Smart charger.

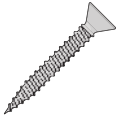
5.1.2. Required tools

Spirit level	Size 3 flathead	TX15 Torx	Voltage tester
			
Hammer	Screws 5x35 mm (4x)	Appropriate wall plugs (4x) (if applicable)	RJ10 Crimping tool
			

5.1.3. Required wiring and electrical protection

	16 A	32 A
Wiring cross section 1-phase*	3 × 2,50 mm ² , solid wire*	3 × 6,00 mm ² , solid wire*
Wiring cross section 3-phase*	5 × 2,50 mm ² , solid wire*	5 × 6,00 mm ² , solid wire*
Mains Circuit Breaker (MCB)	20 A, B/C-characteristic	40 A, B/C-characteristic
Residual Current Device (RCD)	30 mA, Type A	
Data cable	Shielded UTP cable or 4×0,25 mm ² cable	

* max 25 m cable length

5.2. Install the power cable in the consumer unit

1. Switch off the Main Circuit Breaker (MCB) in the consumer unit to cut power to the main grid.
2. Lay down a power cable and data cable between the consumer unit and the installation location of the charger.
3. It is advised to connect the charger to your internet network with an Ethernet cable instead of using Wi-Fi. Therefore, lay down an Ethernet cable between your internet modem and the charger.
4. Install a dedicated 30 mA, Type A Residual Current Device (RCD), or use an available 30 mA, Type RCD.
5. Strip the wires of the power cable.
6. Connect the power cable wires to the dedicated RCD in the consumer unit.

5.3. Install the Sensorbox in the consumer unit

1. Mount the Sensorbox to a free location in the consumer unit.

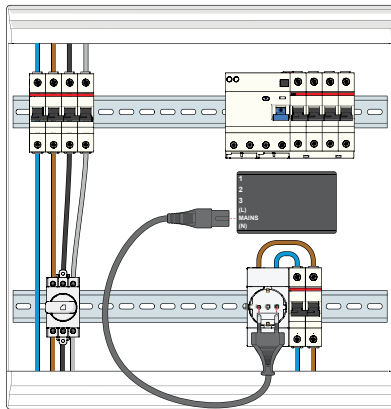

2. Plug the mains input cable into the Sensorbox.
3. Plug the other end of the mains input cable into a power outlet connected to the same phase as L1 of the charger.

Note: The mains input is orientation sensitive. If the mains plug is inserted upside down, the measurements of the Sensorbox will be inaccurate. Check the markings on the Sensorbox for the correct orientation, check the correct position of L and N.

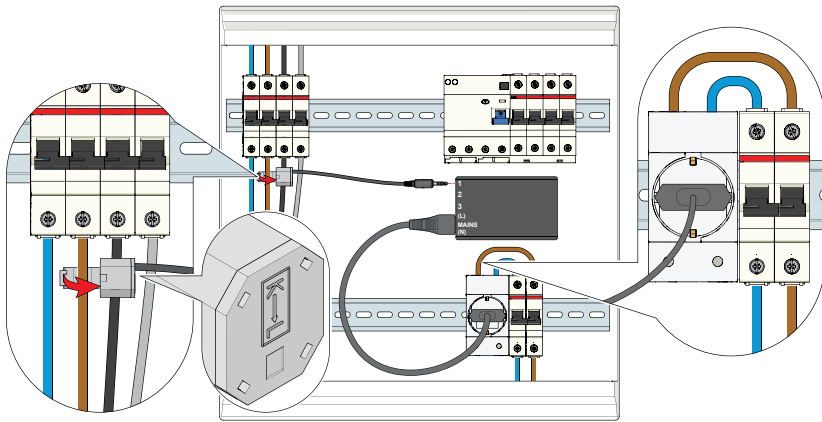

4. Check on which phase of the main power grid the power outlet is connected.
5. Place a current transformer around the same phase wire of the main power grid, between the main fuse and the consumer unit.
6. Insert the 3,5 mm jack of the current transformer to the L1 input on the Sensorbox.

Note: For correct functioning of the Sensorbox, you must install this current transformer around the same phase as the power supply (L).

Note: Make sure the arrow on the current transformer points towards the entry point of the main power grid. See the image below for more information on the correct mounting location of the CT clamps.

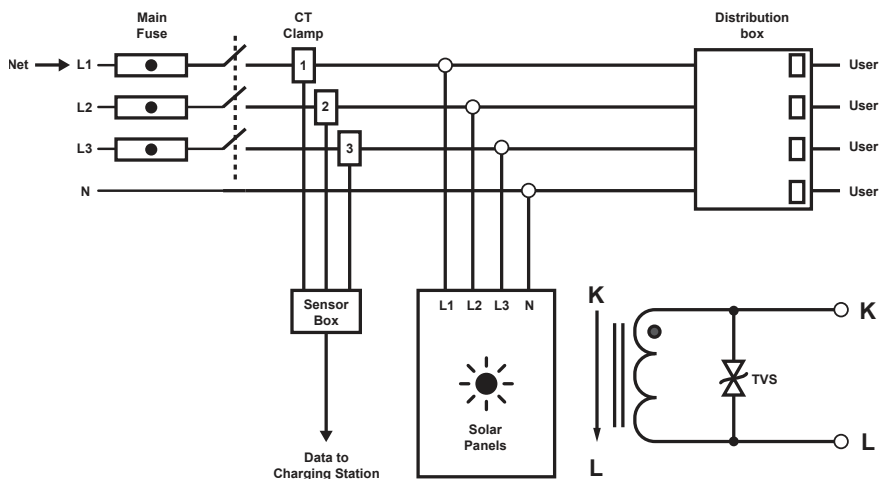

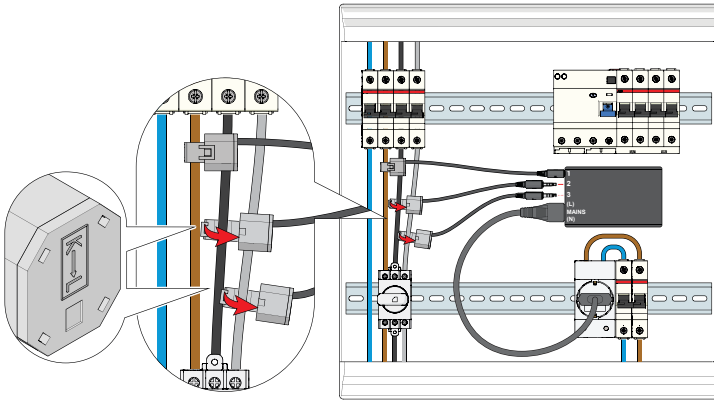

7. Place the remaining current transformers around the other phase wires of the main power grid, also between the main fuse and the consumer unit/solar panel connections.
8. Insert the 3,5 mm jacks of the current transformers to the L2 and L3 input on the Sensorbox.

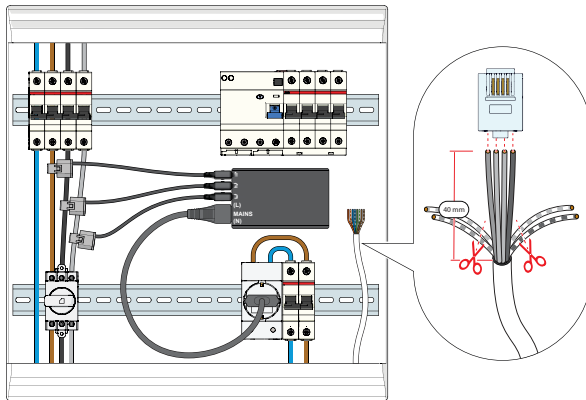

9. Strip the wires of the data cable (not included).
10. Insert four wires of the data cable into the RJ10 connector.
11. Secure the wires to the RJ10 connector. Use a RJ10 crimping tool.
12. Write down the colours and order of the inserted wires of the data cable.

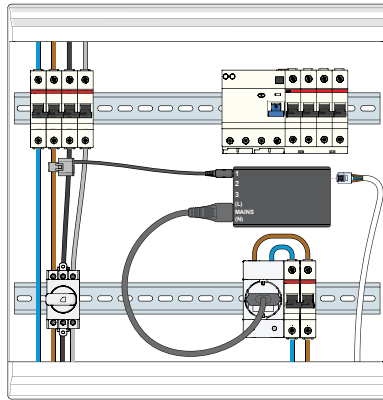

13. Insert the RJ10 connector into the Sensorbox.

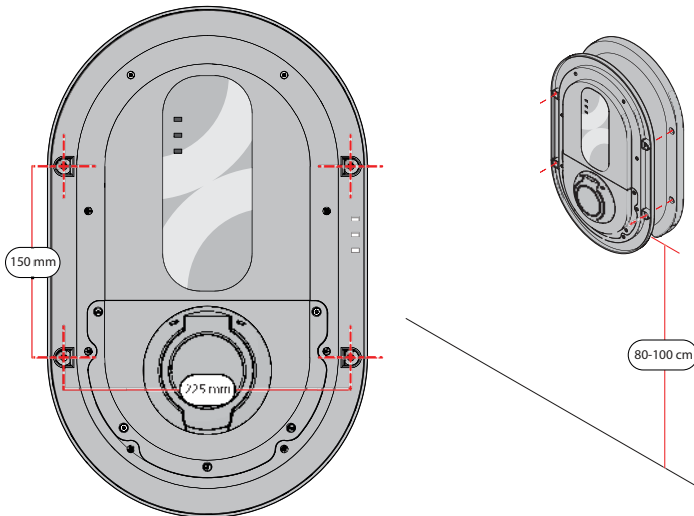

1. Tape the provided drilling template to the wall at the installation location, with the bottom of the template about 80-100 cm above the ground.
2. Ensure the template is level. Use a spirit level.

Alternatively

1. Hold the charger against the wall at the installation location, with the bottom of the charger about 80-100 cm above the ground.
2. Ensure the charger is level. Use a spirit level.

3. Mark the locations of the holes in the charger housing on the wall.
4. Carefully remove the charger and lay it on a flat, stable and dry surface.

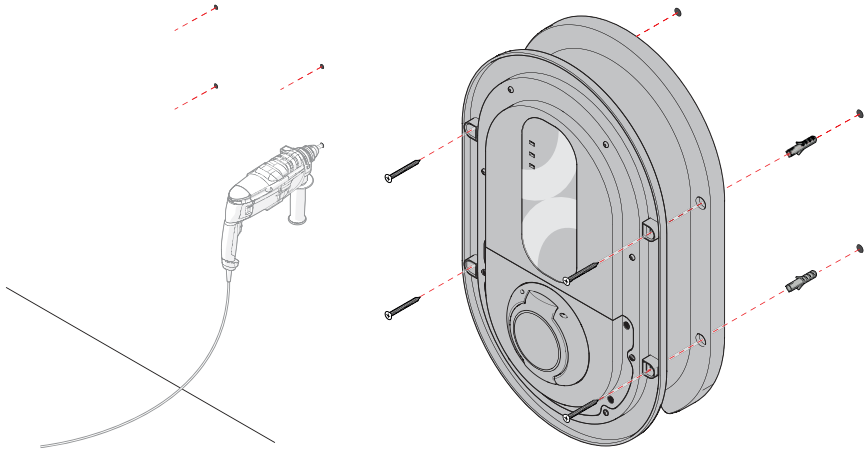

5. Drill the holes in the wall. Use an appropriate drill and drill bit.
6. Insert wall plugs, if applicable.
7. Align the charger with the holes in the wall and secure it with four 5×35 mm screws (not included).

5.4. Connect the power cable to the charger

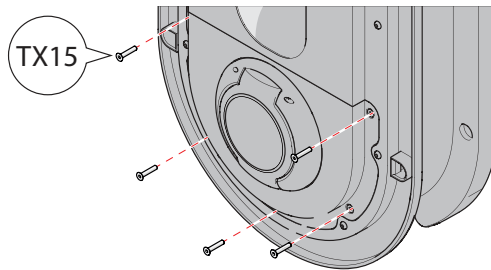

1. Remove the five Torx screws from the housing lid. Use a size TX15 screwdriver.
2. Move the housing lid to the side to access the inner circuitry of the product.

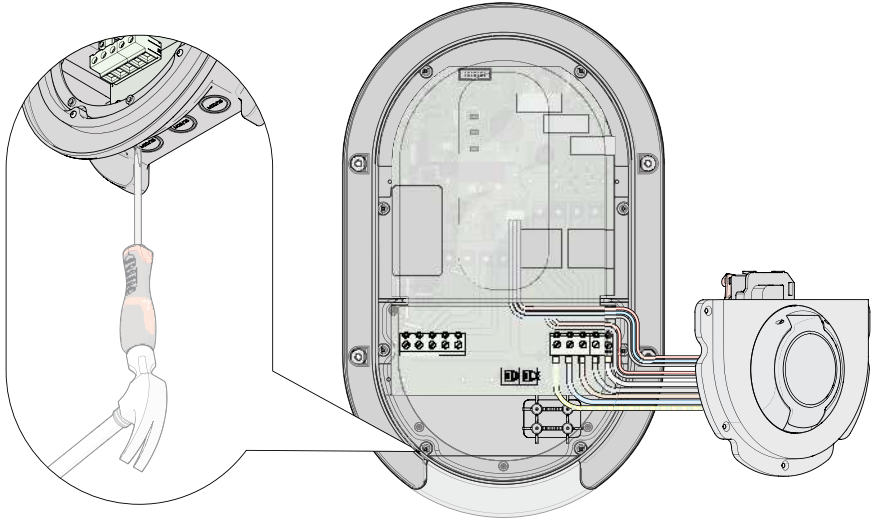

3. Carefully remove the left cable inlet cover. Use a flathead screwdriver and hammer.

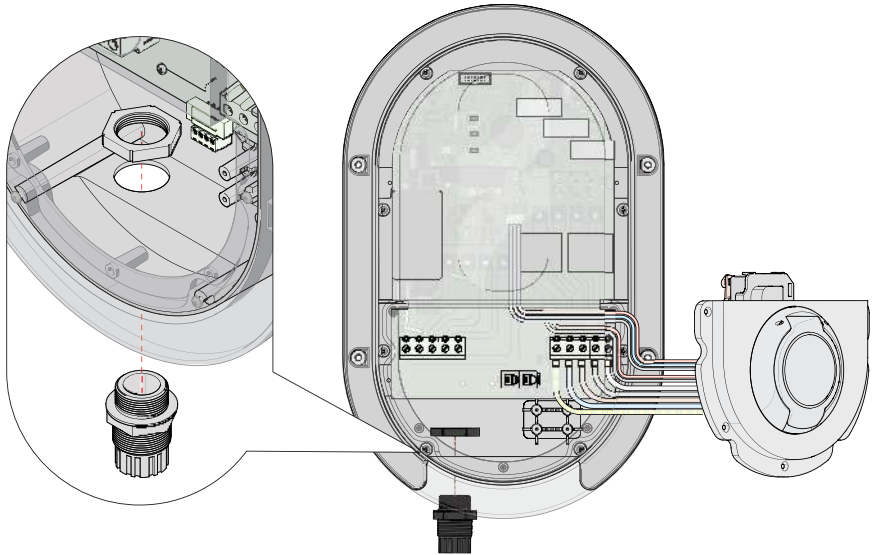

4. Remove the sealing nut from the cable gland.
5. Insert the cable gland through the left cable inlet.
6. Secure the cable gland with the locknut.

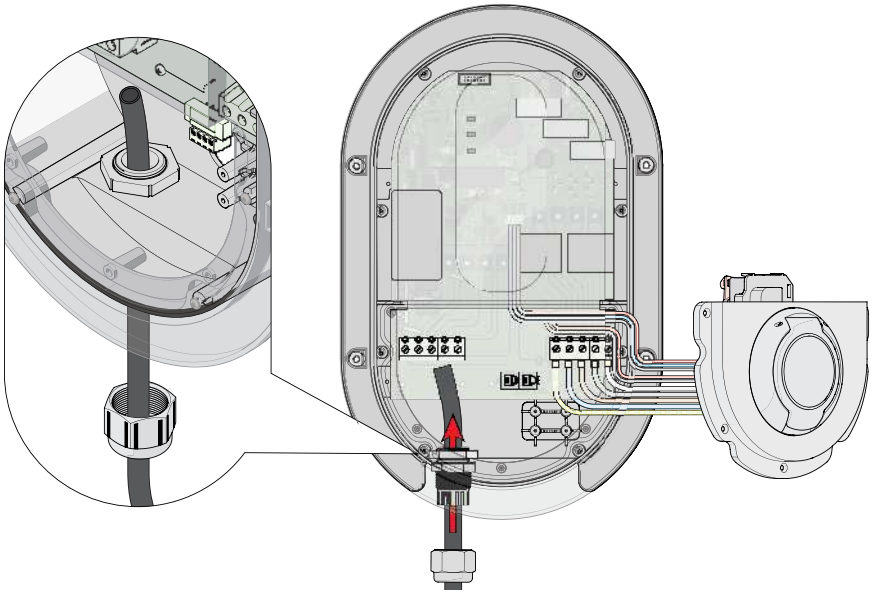

7. Guide the power cable through the sealing nut.
8. Guide the power cable through the cable gland.

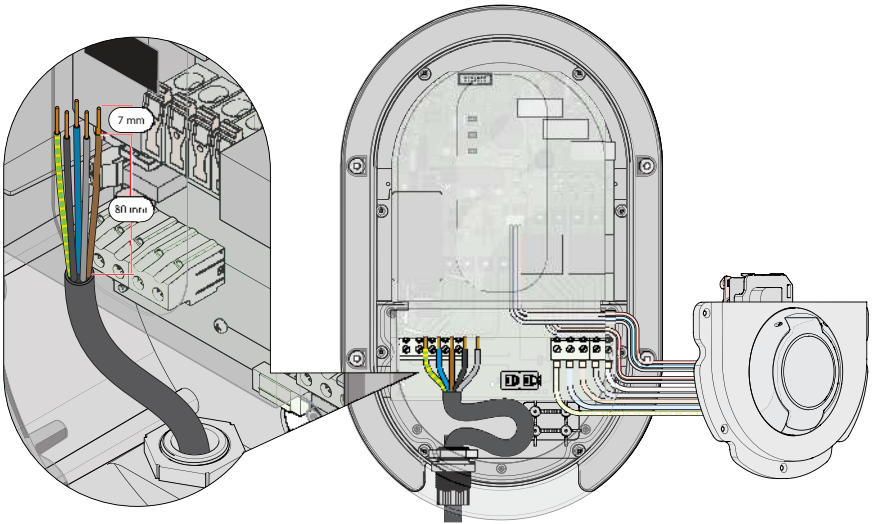

9. Strip the wires of the power cable.

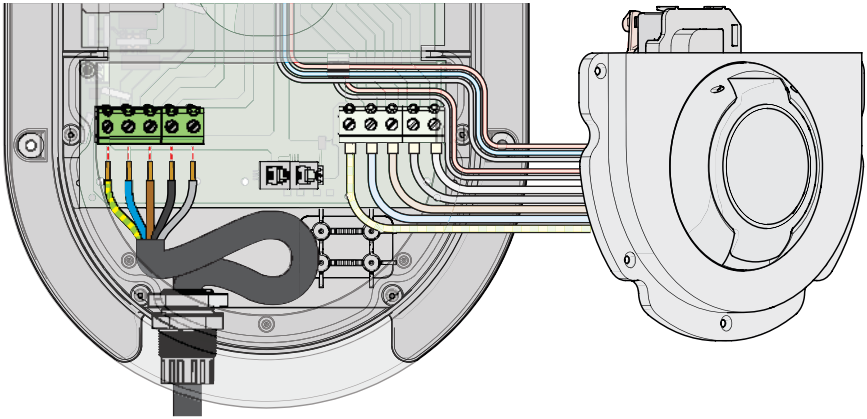

10. Connect the stripped wires to the correct terminals of the left terminal block.

Earth = Green/Yellow L2 = Black*

N = Blue L3 = Gray*

L1 = Brown * for 3 phase installation only.

11. Secure the wires to the terminals using a voltage tester screwdriver.

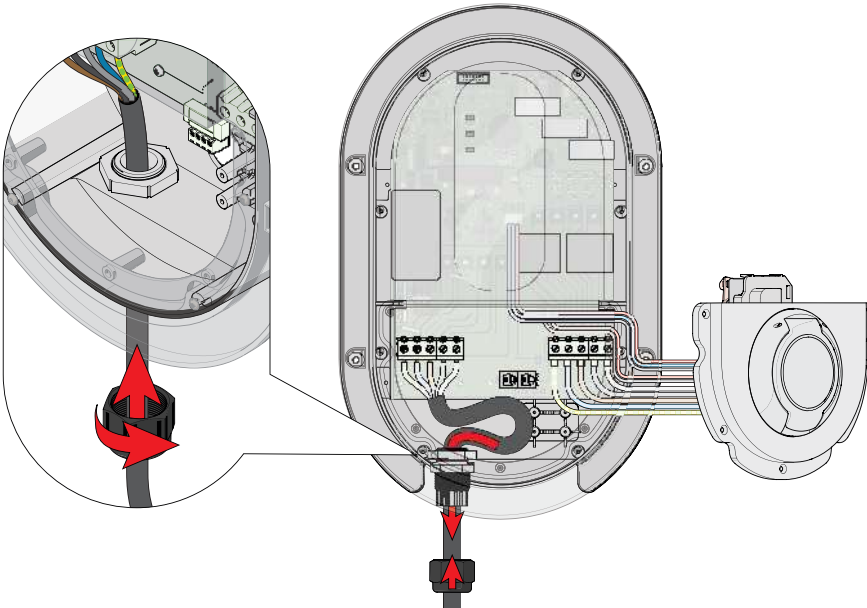

12. Gently pull the excess power cable out of the charger.

13. Secure the power cable in place by tightening the sealing nut onto the cable gland.

5.5. Install the data cable in the charger

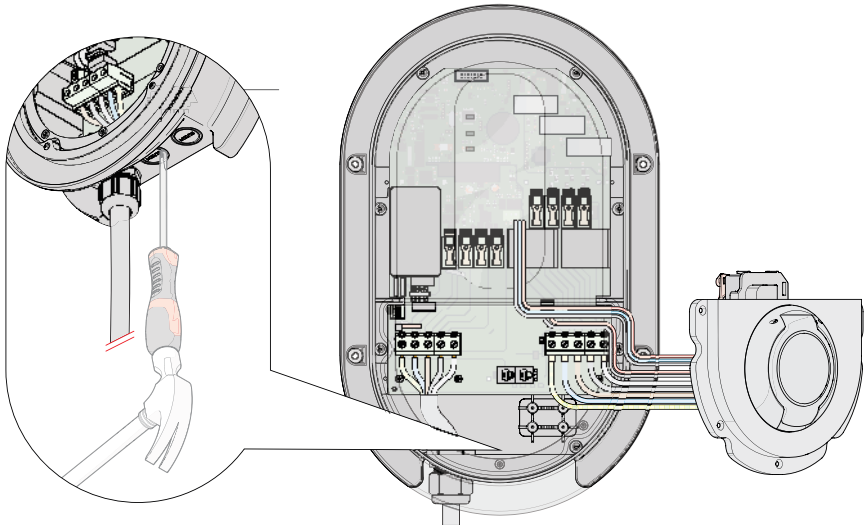

1. Carefully remove the centre cable inlet cover. Use a flathead screwdriver and hammer.

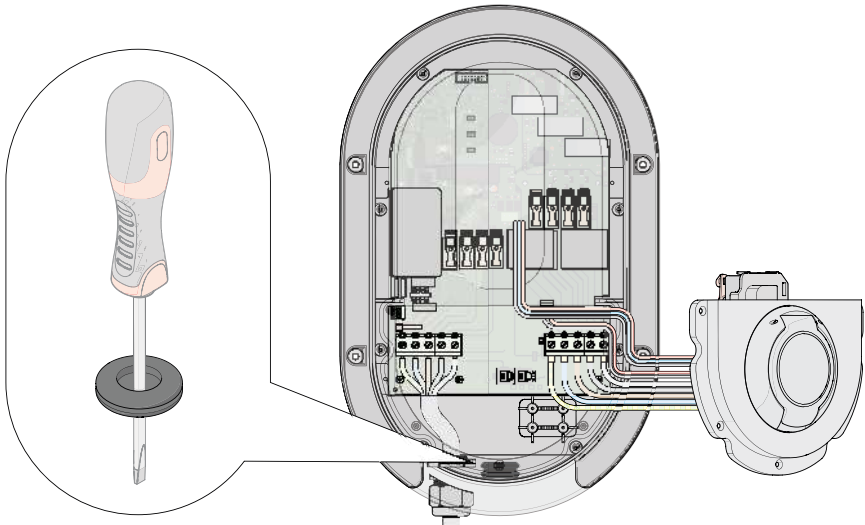

2. Place the foam insert into the cable gland or punch a hole in the centre of the rubber cable grommet using a screwdriver.
3. Insert the cable gland with foam insert or rubber cable grommet into the centre cable inlet.

4. Guide the data cable through the cable gland with foam insert or rubber grommet.

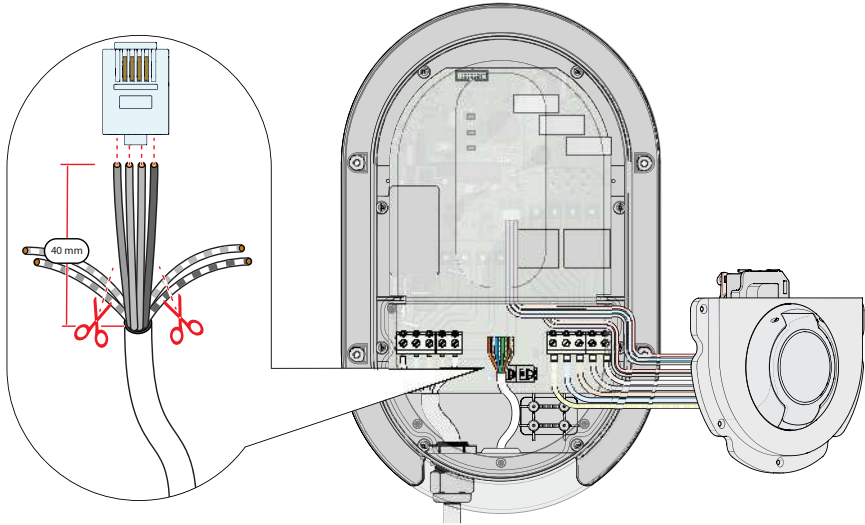

5. Strip the wires of the data cable.
6. Take the four full coloured wires.
7. Remove the unused wires.
8. Insert the wires into the RJ10 connector in the exact same order as in the Sensorbox.
9. Secure the wires to the RJ10 connector. Use a RJ10 crimping tool.

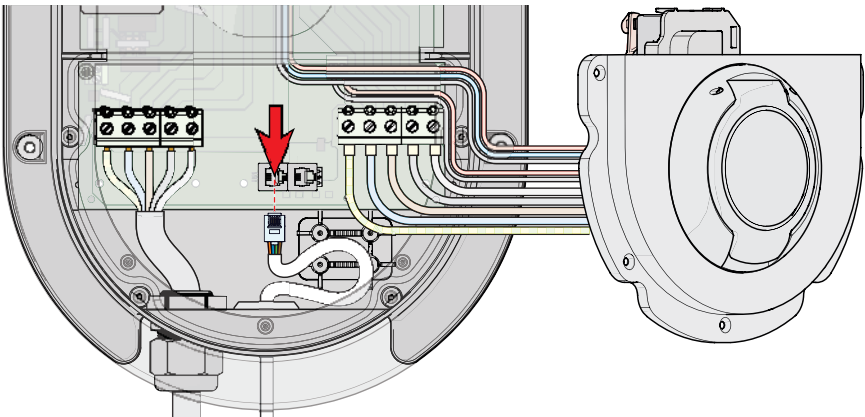

10. Insert the RJ10 connector into the left RJ10 port of the charger.

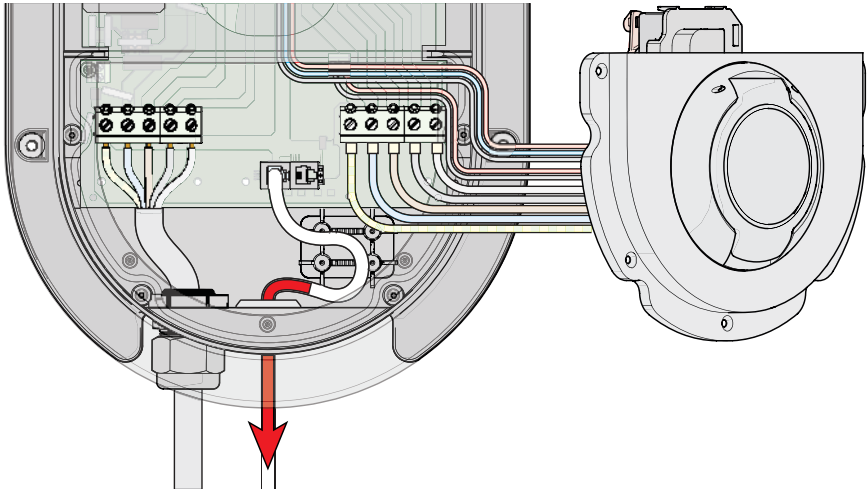

11. Gently pull the excess data cable out of the charger.

Note: When you use Ethernet, which is preferred over Wi-Fi, connect an Ethernet cable with the **pig-tail** Ethernet connector inside the charger.

If you have purchased a single charger, please continue to chapter 5.8.

If you have purchased multiple chargers and want to use the **Power Sharing** feature, please continue to chapter 5.7.

5.6. Install a data cable between two chargers for Power Sharing

5.6.1. In the Main Controller

1. Lay down a data cable between the Main Controller and first Sub charger.
2. Guide the second data cable alongside the existing data cable through the cable gland with foam insert or rubber grommet.

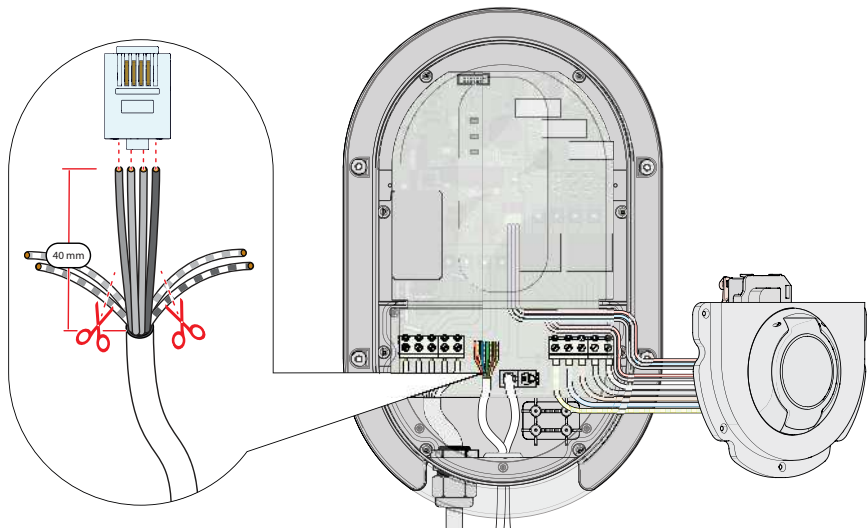

3. Strip the wires of the data cable.
4. Match the coloured wires to the wires that are already connected to A, B and GND of the RJ10 connector.
5. Remove the unused wires.

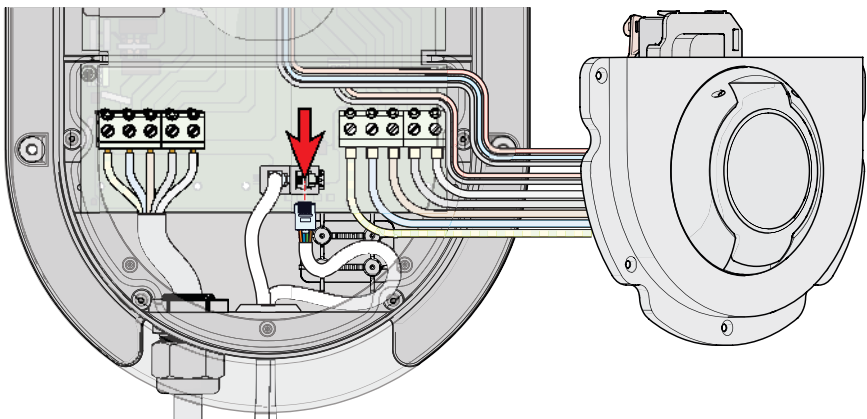

6. Insert the wires into a second RJ10 connector.
7. Secure the wires to the terminals using a RJ10 crimping tool.
8. Insert the RJ10 connector into the right RJ10 connector of the charger.
9. Gently pull the excess data cable out of the charger.

5.6.2. In the Sub charger

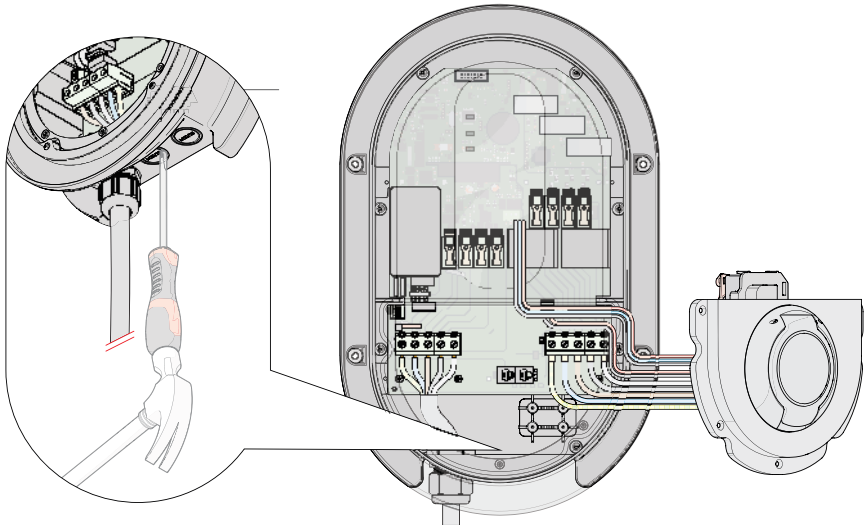

1. Carefully remove the centre cable inlet cover. Use a flathead screwdriver and hammer.

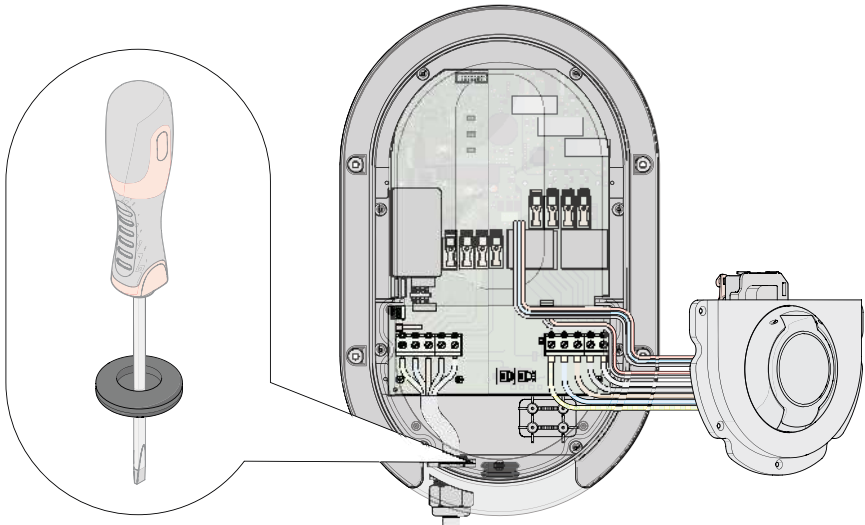

2. Punch a hole in the centre of the rubber cable grommet using a screwdriver.
3. Insert the cable gland with foam insert or rubber cable grommet into the centre cable inlet.
4. Guide the data cable through the cable gland with foam insert or rubber grommet.

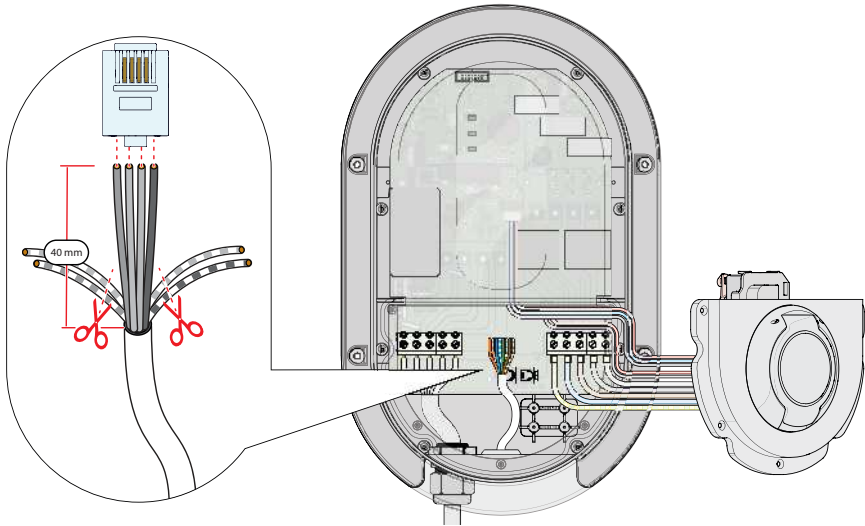

5. Strip the wires of the data cable.
6. Take the three solid coloured wires.
7. Remove the unused wires.
8. Insert the wires into the RJ10 connector in the exact same order as in the main controller charger.
9. Secure the wires to the RJ10 connector. Use a RJ10 crimping tool.

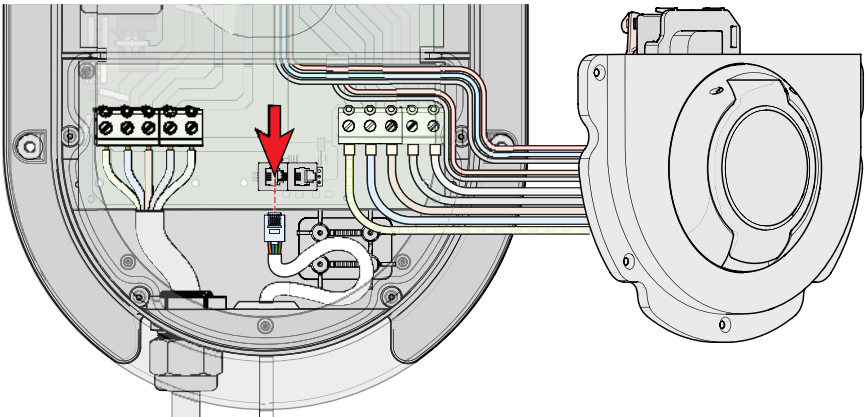

10. Insert the RJ10 connector into the left RJ10 port of the charger.

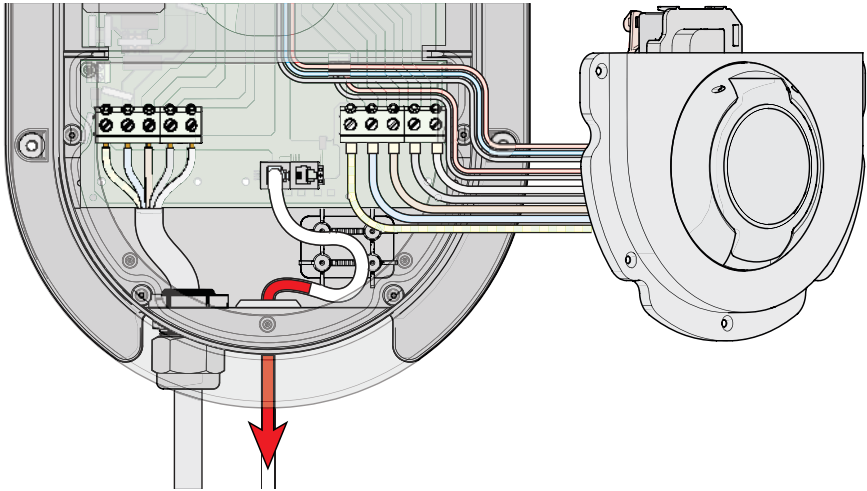

11. Gently pull the excess data cable out of the charger.
12. Repeat the installation steps for Sub chargers in daisy chain configuration.

Note: Only the Main Controller is directly connected to the Sensorbox.

Note: When you use Ethernet, which is preferred over Wi-Fi, connect an Ethernet cable with the **pig-tail** Ethernet connector inside the charger.

5.7. Checks before finishing the installation

- Check if all phase, neutral and earthing wires are properly connected.
- Check if the data cables are wired correctly and the order of the coloured wires matches on both sides.
- Check if all cables are free of damage and are properly secured.
- Check if the current transformers are properly installed around the phase wires of the main power grid.
- Check if the current transformers are plugged into the correct phase inputs of the Sensorbox.
- Check if the housing is correctly closed and no loose wires are visible or exposed.

5.8. Finish the installation

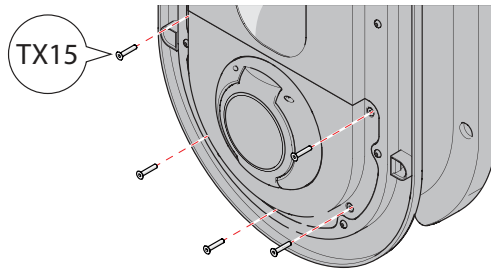

1. Secure the housing lid in place with the five Torx screws using a size TX15 screwdriver.

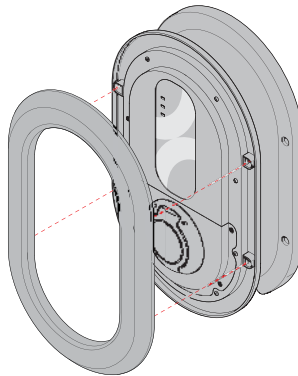

2. Click the front cover ring on the charger housing.

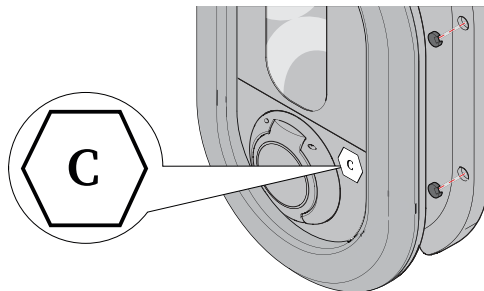

3. Place the four screw caps to cover the mounting screws.
 4. Apply the Fuel Identifier sticker on the housing, next to the outlet or plug holder.
- Congratulations, you have finished installing the charger. Before the charger is ready for use, you must first commission the charger.

6. Commissioning

Switch the Main Circuit Breaker (MCB) in the consumer unit back on to provide power from the main grid to the charger(s). The charger switches on and boots up. The power LED lights up green to indicate the charger is powered.

The booting sequence is finished when the Ready/Charge LED lights up.

Note: For optimal use of the charger, connect the charger to the internet via Ethernet cable. If that is not possible, connect via Wi-Fi.

6.1. Note down the unique passcode of the charger

It is important to save the unique Bluetooth® wireless technology passcode of the charger. This code is necessary when the charger has to be restored to the factory settings. The unique passcode of your charger is a 6-digit code.

6.2. Download the Ratio EV Charging App

Install the Ratio EV Charging App and create an account before use.

1. Scan the QR code.

Alternatively, go to the Google Play store or App Store on your device and search for "Ratio".

2. Download the Ratio EV Charging App.
3. Follow the steps in the app to login to your account or create a new account. See chapter 6.4. for more information.



Note: During a first installation, the **Advanced settings** menu must always be opened and run through.

6.3. Initial configuration of the charger

NOTICE

The **Advanced settings** menu should only be accessed by a qualified technician. In this menu you can adjust settings that, if entered incorrectly, could damage the installation.

Before the charger is ready for use, you need to configure the initial setup parameters:

To enter the **Advanced settings** menu, select the charger, tap the gear icon at the bottom right corner, and select **Advanced settings**.

Note: Entering the **Advanced settings** menu is only possible if you are within Bluetooth® wireless technology range of the charger.

Note: It is not possible to enter the settings menu during a charging session.

Configure the following settings for the charger.

Power Sharing configuration If you have a single charger, leave this option Disabled.
If you have multiple chargers interconnected with data cables, activate **Power Sharing**.
Set the charger that is directly connected to the Sensorbox to: Main Controller
Available options: Disabled, MAIN, SUB1, SUB2, SUB3.

Note: Make sure every sub charger is set to a unique SUB number.

Note: Make sure only one of the interconnected chargers is set to “Main Controller”.

Note: PureSolar mode is not compatible with **Power Sharing**. If you enable **Power Sharing**, the charge mode will be set to SmartSolar.

Home connection maximum current Set this value to the size of the grid connection as measured by the CT clamps. E.g. if the home has a 3× 25A connection, set this value to 25A. This value is used for **Dynamic Load Balancing**.

Charger connection maximum current Set the maximum allowed charging power of the charger.
Range: 6A – 32A.

Note: This value must be lower than the rating of the used MCB.

Number of solar power phases Select the amount of phases on which the solar panel installation is installed.

Note: This value is only used when the charge mode is set to PureSolar or SmartSolar.

6.4. Overview of the Ratio EV Charging App

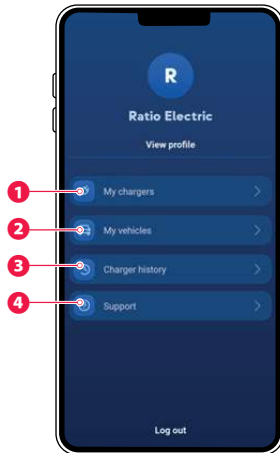

- 1 Manage connected chargers or add a new charger with the unique Bluetooth® wireless technology passcode found on the included label.
- 2 Manage connected vehicles or add a new vehicle.
- 3 Overview of recent charging sessions.
- 4 Shows the current version of the Ratio EV Charging App

Note: Adding vehicle information is recommended for a detailed overview of your charging activity.

Note: It is not mandatory to register your vehicle, but if you don't register you will miss certain functionalities. Instead of a license plate, you can also enter a name.

6.5. Connect the charger to the Ratio EV Charging App

1. Tap **My chargers** on the home screen.
2. Tap **Add charger**.

A list of all available chargers is shown.

3. Check the serial number of the charger on the label and select the charger with the corresponding serial number from the list of available chargers.
4. Enter the 6-digit Bluetooth® wireless technology passcode and press **Connect**.

If the connection is successful, the charger is now added to the My chargers screen.

6.6. Testing solar charging functionality

It is important for the correct functioning of the charger to check if the Sensorbox is connected properly.

1. Temporarily switch off the solar panel installation.
2. Check if the LED on the Sensorbox periodically blinks red three times.
3. In the App, go to the **Advanced settings** and select **Actual current**.
4. Check the values for L1, L2, and L3. The measurements should only show positive values.
5. If any of these values is negative, reverse the 3.5 mm jacks of L2 and L3, and check if the values are positive.
6. Switch the solar panel installation back on.

On the Sensorbox, the LEDs of the phase(s) on which the solar panel installation is connected should start blinking green when there is power fed back to the grid.

7. Check if the **Actual current** screen in the App shows negative power values when power is fed back into the grid by the solar panel installation.

Note: If no power is currently fed back into the grid by the solar panel installation, perform this test procedure again when there is power fed back to the grid.

6.7. Updating the charger

Ratio recommends to always install available firmware updates. Firmware updates keep the data security of the charger up-to-date and occasionally add new features.

Updates are performed sequentially. This allows the system to offer multiple updates in succession. Always install all updates to ensure you are using the latest version. Read the release notes on the Ratio website or in the AppStores to learn about new features and improvements to the system.

Whenever a firmware update is available, the update icon  is shown next to the charger in the **My Chargers** screen.

1. Tap the button for the charger to install the update.
 2. Tap **Install now** to install the update or tap **Install later** to delay the update so you can immediately charge your EV.
- The update announcement reappears the next time you access the **My Chargers** screen.

Note: make sure that the charger stays powered and connected to the internet during the update. Power/network outages can cause the update to fail.

The Ratio EV Charging App does not have to remain opened during the update.

While the update is in progress, the  icon is shown next to the charger in the **My Chargers** screen.

The update may take a few minutes. After the update, the charger reboots and is ready to use.

NOTICE

Do not use the charger during the update process.

3. After the charger firmware update, check in the AppStore or PlayStore if there is an update available for the Ratio EV Charging App and update it if available.

Regularly check for available updates in the **My Chargers** screen of the Ratio EV Charging App.

Note: Using an old version of the Ratio EV Charging app may lead to compatibility issues and is not recommended.

7. Use

7.1. Start charging

1. Plug your charging cable into the socket of the charger. (socket version only)
2. Plug the other side of your charging cable into your EV.
The Ready/charge LED lights up to indicate that the EV is detected.
3. Open the Ratio EV Charging App.
4. Tap **My chargers**.
5. Tap the charger you want to use.

The Stand-by screen appears.

6. Select your car or select Continue without registration.
7. Tap **Start** to start charging your vehicle.

7.2. During charging

During a charging session, the measured power usage is displayed in kW in the Ratio EV Charging App.

7.2.1. Charging paused

In case there is less than 6A available on the main grid, the charging session will automatically be paused.

Switch off any power demanding devices or wait until more than 6A power is available.

As soon as there is sufficient available power, the charging session will automatically resume.

7.3. Stop charging

The charging session will stop automatically when the EV is charged to the maximum battery level, set in the EV.

You can manually stop the charging session by pushing the **Stop** button in the App or unlocking your car.

1. Unplug the EV charging connector from the EV.
2. For socket version: Unplug the EV Charging connector from the charger.
For fixed cable version: Wrap the fixed cable around the charger and insert the connector into the plug holder in the front of the charger.

The Ratio EV Charging App no longer shows current directions and power usage values.

8. Settings

To edit your settings, do the following:

1. Tap **My Chargers** on the homepage of the app.
2. Tap the charger you want to set up.
3. Tap the gear wheel icon on the bottom right of your screen.

Here you can edit the following settings:

Wi-Fi	Connect your charger to a Wi-Fi network.
Start Mode	Manual: start charging mode using the app. Auto: start charging mode directly after plugging in your vehicle.
Cable settings (socket version only)	Select the locking procedure of your charging cable.
Minimum charging current	Set the minimum required charging power of the charger. Range: 6A - 16A.
Maximum charging current	Set the maximum allowed charging power of the charger. Range: 6A - 32A.
Charge mode	Set the desired charge mode.
Note: See chapter 2. for more information on the charge modes.	
SmartSolar minimal charging current	Set the minimum required charging power of the charger for the SmartSolar charge mode Range: 6A - 16A.
PureSolar minimal charging current	Set the minimum required charging power of the charger for the PureSolar charge mode. Range: 6A - 16A.
SunOffDelay	Set a delay time for the charger to stop charging after net power generation is no longer detected. Range: 2 min - 60 min.

SunOnDelay

Set a charging delay time after net power generation is detected (e.g. from solar panels).

Range: 1 min – 20 min.

NOTICE

The advanced settings menu should only be accessed by a qualified technician. In this menu you can adjust settings that, if entered incorrectly, could damage the installation.

9. Maintenance

Ratio chargers are practically maintenance-free, aside from periodic cleaning of the housing.

1. Switch off the charger before cleaning the housing.
2. Clean the Smart/Solar Charger using a soft cloth lightly moistened with mild detergent solution.

⚠ WARNING**Risk of electric shock**

- Switch off the charger before cleaning the housing.
- Be careful when cleaning the inlets and socket, do not use excessive amounts of water to avoid water leaking into the charger.

NOTICE**Risk of damage to the product**

- Do not use aggressive chemicals to clean the charger.
- Do not use coarse cleaning tools that may damage or scratch the surface of the charger.
- Never use any type of abrasive pad, scouring powder, or flammable solvents such as alcohol or benzene.

10. Troubleshooting

The charger is equipped with monitoring software that detects faults and displays them as error messages in the App. Every fault has a specific error code for easy identification. An overview of the error codes is shown below.

Error code	Fault	Possible solution
100	CP error, faulty values or short circuited. Possible causes: Damaged charging cable Dirty connectors Issue originating from the EV.	Switch off the power to the main grid. Clean the connector(s) of the charging cable. Check the cable for any visible damage. Switch the power to the main grid back on. Try charging with a different charge cable. Try charging a different EV. Try charging the EV with a different charger. If the error persists: Please contact Ratio or a qualified electrician to have the cable inspected/replaced.
101	Grounding fault Possible causes: Damaged charging cable Damaged charger	Switch off the power to the main grid. Switch the power to the main grid back on. If the error persists, Please contact Ratio or a qualified electrician to have the charger inspected.
102/112	Maximum temperature exceeded while charging. Possible cause: long, high current charging sessions in high ambient temperatures.	Allow the charger to cool down before resuming the charging session. When the charger has cooled down, the error code disappears and the charger returns to regular operation.
111	No communication between the charger and the Sensorbox.	Check if the connectors are properly inserted in the Sensorbox and charger. Check if the Sensorbox is powered. Check the data cable for visible damages. Replace the data cable if necessary.

If there is no error code:

- Check the charger, charge cable and connector for any visible damage.
- Make sure the power LED on the charger is on.
- Make sure that the charge cable is properly inserted and locked into your EV.

If you cannot find the reason why your charger is not working properly, please contact your local reseller or Ratio Electric B.V.

Points of attention if the App shows incorrect values while the charger is in Smart, SmartSolar or PureSolar mode:

- Make sure the arrows on the current transformers point towards the entry point of the main power grid.
- Make sure the current transformers L1, L2 and L3 are connected according to the phase sequence (Sine).
- If the charger indicates deviating values, it can help to switch the CT terminals on L2 and L3 on the Sensorbox.
- The mains input cable of the Sensorbox must be plugged into a power socket connected to the same phase as L1 of the charger.

Note: the Sensorbox 230VAC connection is phase (L) and neutral (N) sensitive.

- The Sensorbox flashes red if no solar energy is being generated (3x red).

For example, if solar energy is generated and energy is fed back to grid on phase 1, the LED will flash 1x green and 2x red in succession.

11. Service

To avoid risk of electric shock, only qualified electricians should perform service or maintenance on the charger. If your charger is in need of servicing, please contact Ratio, your local vendor or a qualified electrician.

12. Data protection

We refer you to our privacy statement on our website.

13. Warranty

Ratio Electric B.V. warrants this product to be free from defects in material, manufacture and design for a period of 3 years after the date of purchase. If this product is defective in materials, manufacture or design during this warranty period, Ratio Electric B.V. will, at its option, repair or replace the product.

Repair parts and/or replacement products may be either new or reconditioned at Ratio Electric B.V. discretion.

This limited Carry-In Warranty does not include service to repair damage from improper installation, improper connections with peripherals, external electrical fault, accident, disaster, misuse, vandalism, unauthorized alteration or repair, abuse or modifications to the product not approved in writing by Ratio Electric B.V.

Any evidence of an attempt to disassemble the Smart/Solar Charger will void this warranty.

Any service repair outside the scope of this limited warranty shall be at applicable rates and terms then in effect.

14. Disposal

If the charger is defective beyond repair, or you no longer wish to use the charger, please recycle the charger according to local applicable rules and guidelines regarding the disposal of electrical devices.



For more information, check our website.



Ratio Electric B.V.

Ambachtsstraat 12

NL – 3861 RH Nijkerk

The Netherlands

Tel. +31-33-2452360

info@ratio.nl

www.ratio-electric.com